

**CONTENTS**

Storm BS (balanced) Friction Hinges 10" and 16"	08.3
Storm Friction Hinge 22"	08.5
Storm B (balanced) Friction Hinge 26"	08.7
Standard Defender Hinges 6" - 8" - 10" - 12" - 16" - 20" and 24"	08.9
Defender Restrictor Stays 4" - 6" and 9"	08.11
Restrictor Stay Storm 8"	08.12
Detachable Restrictor Stays 4" - 6" - 8" and 10"	08.13
Drop-in Limit Stop	08.14
Handing of Windows	08.15
Handing of Doors	08.16
Spring Loaded Hinge	08.17
Ball Bearing Hinge for Doors	08.18
Adjustable 3 Way Hinge	08.19
Drill-in Hinge 2 Parts and Covers	08.20
Drill in Hinge 3 Parts and Covers Kit	08.21
3-D Adjustable Hinges and Covers	08.22
Covers and Shim Set for Series 6-C8836	08.23
Light Duty Butt Hinge for Sashes up to 60 kg	08.24
3-D Hinge	08.25



Securistyle Hinge for Windows



STORM BALANCED HINGE

Storm BS (balanced) friction hinges 10" and 16"

Description	Color	Weight kg	PU	Part Number
Storm BS hinge 10"	Stainless Steel	15,3	25	6-C8648-10-P-8
Storm BS hinge 16"	Stainless Steel	22,0	25	6-C8648-16-P-8

• Use for casement and awning windows

Storm BS (balanced) loose rivets friction hinge 10"

Storm BS loose rivets hinge 10"	Stainless Steel	15,3	25	6-C8654-10-P-8
---------------------------------	-----------------	------	----	----------------

• Use for casement windows only

\* = Color

PU = Packaging Unit



Stainless Steel end locator



Heavy duty friction slider

ADDITIONAL INFORMATION

- Self balancing hinge range
- Designed for enhanced performance on larger windows
- Top hung STORM gives self balanced windows
  - No need for additional support arms
- Composite Stainless Steel & Acetal slide
- Metal end cap
- All metal components made from high grade 304 Stainless Steel
- Proven to conform to American Standards:
  - AAMA 904.1 - 87, 910 - 93 et 101/I.S.2 - 97

Part Number	Hinge Length in/mm	Max Vent Weight kg	Min Vent Height mm	Max Vent Height mm	Max Vent Width mm	Cavity Dimensions mm	Opening Angle ± 2,5°
<b>Awning Hinges</b>							
STORMBS10	10/263	50,0	280,0	762,0	-	16,0 - 18,0	80°
STORMBS16	16/415	63,0	457,0	1120,0	-	16,0 - 18,0	90°
<b>Casement Hinges</b>							
STORMBS10	10/263	38,0	280,0	-	660,0	16,0 - 18,0	80°
STORMBS16	16/415	47,0	450,0	-	838,0	16,0 - 18,0	90°

Dimensions of Storm BS (balanced) friction hinges 10" and 16"

Fitting instructions: Position and Clearances

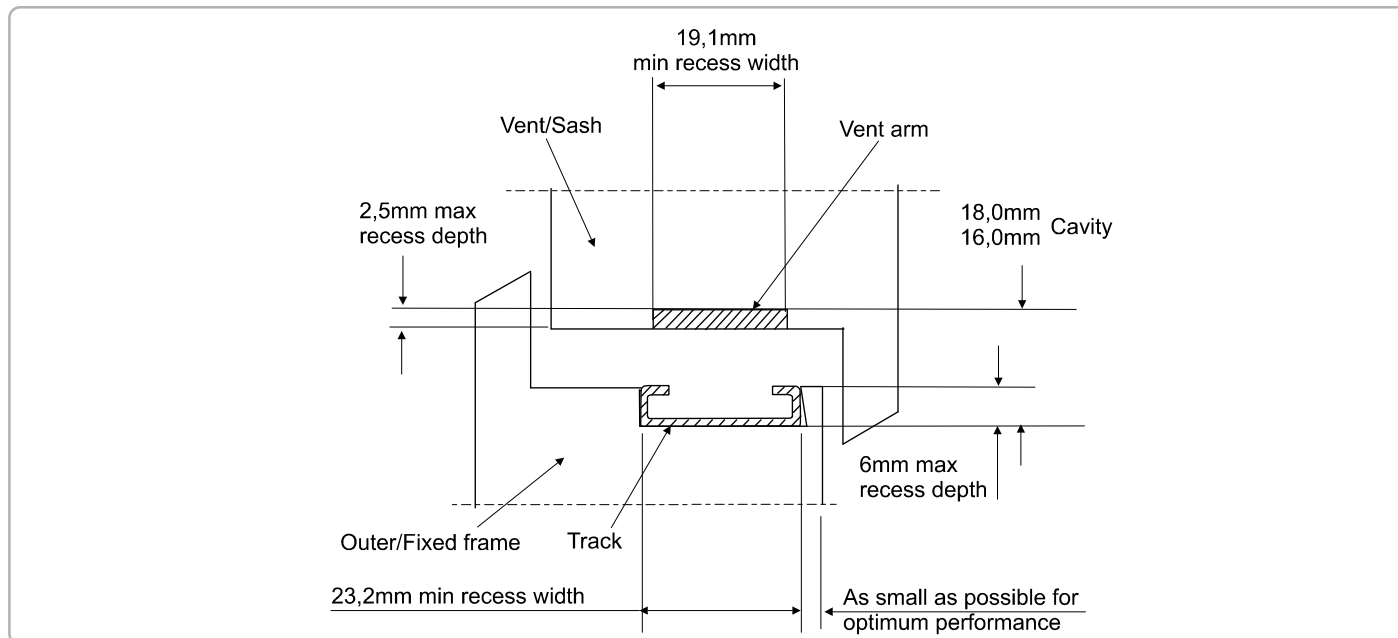

» Dimensions in mm

Fixing hole centre reference

Part Number	Dim. A mm	Dim. C mm	Dim. D mm	Dim. E mm	Dim. F mm
STORMBS10	34,0	165,1	129,8	177,8	218,2
STORMBS16	63,6	241,2	183,0	304,0	370,6

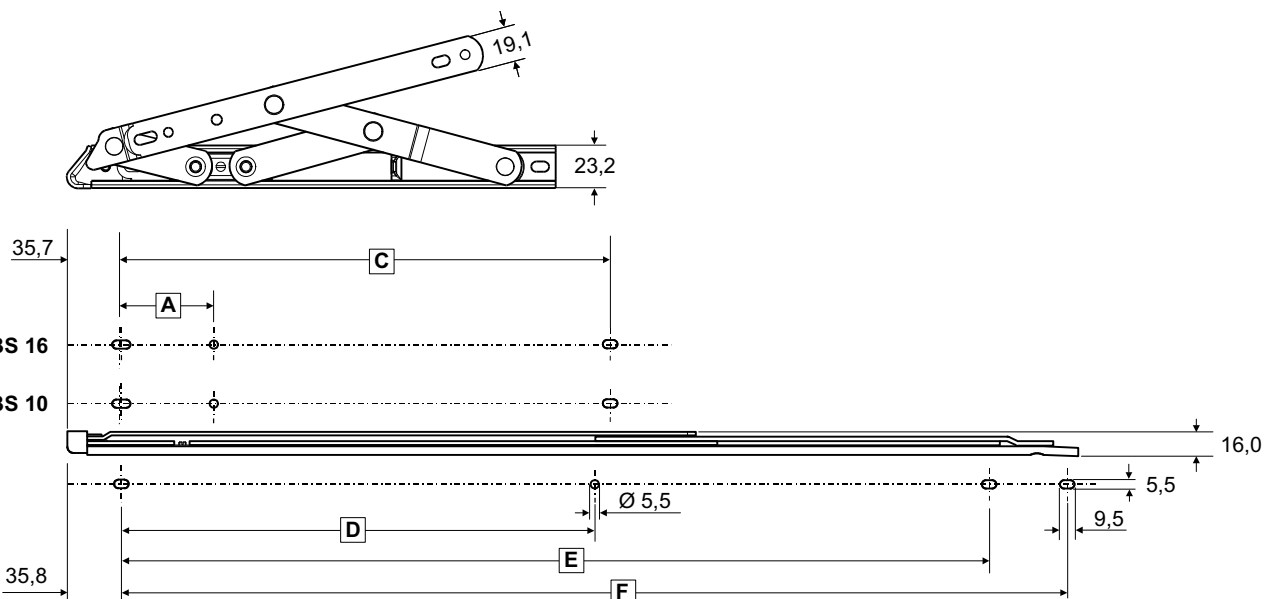

Securistyle Hinge for Windows



STORM HINGE



Stainless Steel end locator



Heavy duty friction slider

Storm friction hinge 22"

Description	Color	Weight kg	PU	Part Number
Storm hinge 22"	Stainless Steel	23,1	20	6-C8645-22-P-8
* = Color			PU = Packaging Unit	

**ADDITIONAL INFORMATION**

- Designed for enhanced performance on larger windows.
- Top hung STORM gives self balanced windows.
  - No need for additional support arms.
- Composite Stainless Steel & Acetal slide.
- Metal end cap.
- All metal components made from high grade 304 Stainless Steel.
- Proven to conform to American Standards:
  - AAMA 904.1 - 87, 910 - 93 et 101/I.S.2 - 97

Part Number	Hinge Length in/mm	Max Vent Weight kg	Min Vent Height mm	Max Vent Height mm	Min Vent Width mm	Max Vent Width mm	Cavity Dimensions mm	Opening Angle ± 2,5°
<b>Awning Hinges</b>								
STORM22	22/567	75,0	1090,0	1321,0	-	-	16,0 - 18,0	90°

Dimensions of Storm friction hinge 22"

Fitting instructions: Position and Clearances

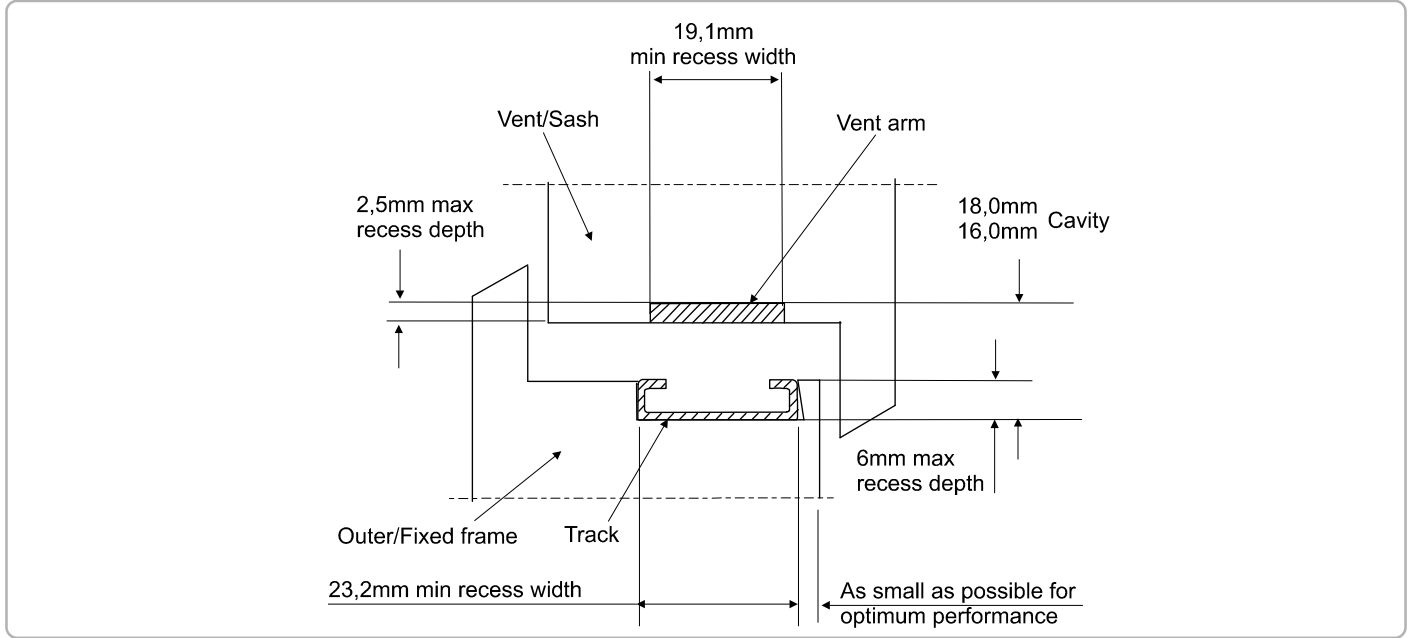

» Dimensions in mm

Fixing hole centre reference

Part Number	Dim. A mm	Dim. B mm	Dim. C mm	Dim. D mm	Dim. E mm	Dim. F mm
STORM22	65,0	165,0	317,4	248,3	418,3	523,0

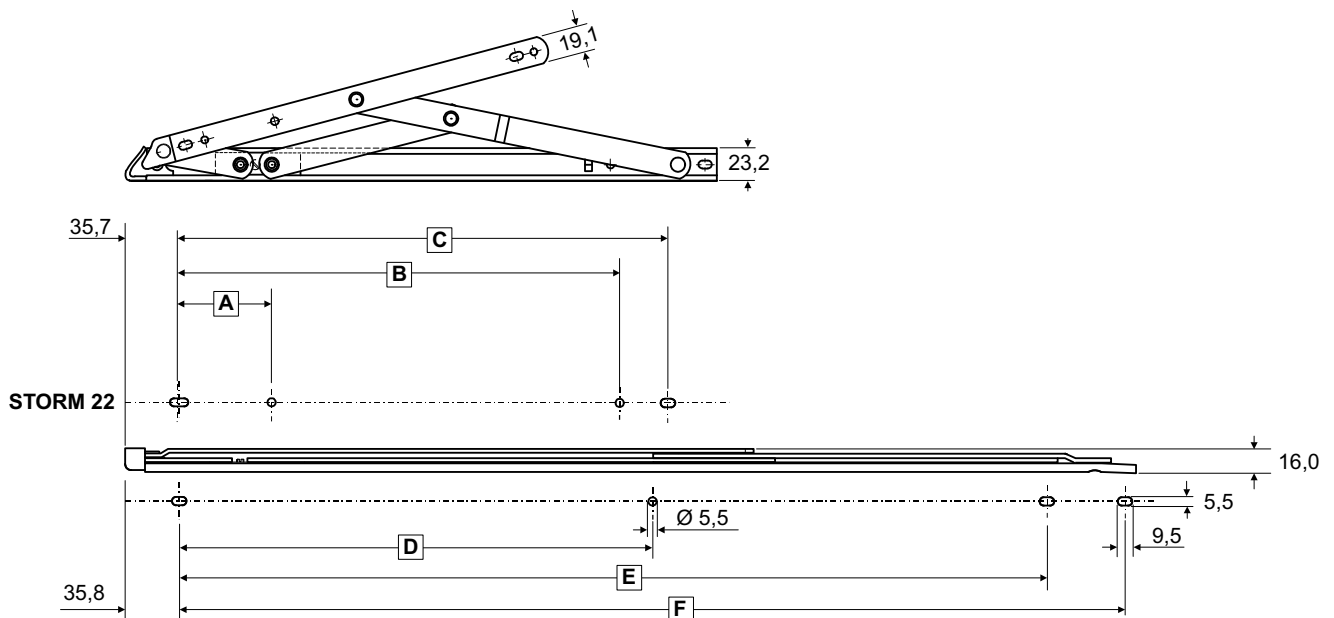

Securistyle Hinge for Windows



STORM BALANCED HINGE



Stainless Steel end locator



Heavy duty friction slider

Storm B (balanced) friction hinge 26"

Description	Color	Weight kg	PU	Part Number
Storm B hinge 26"	Stainless Steel	16,5	10	6-C8646-26-P-8
* = Color		PU = Packaging Unit		

**ADDITIONAL INFORMATION**

- Self balancing hinge range
- Designed for enhanced performance on larger windows.
- Top hung STORM gives self balanced windows.
  - No need for additional support arms.
- Composite Stainless Steel & Acetal slide.
- Metal end cap.
- All metal components made from high grade 304 Stainless Steel.
- Proven to conform to American Standards:
  - AAMA 904.1 - 87, 910 - 93 et 101/I.S.2 - 97

Part Number	Hinge Length in/mm	Max Vent Weight kg	Min Vent Height mm	Max Vent Height mm	Min Vent Width mm	Max Vent Width mm	Cavity Dimensions mm	Opening Angle ± 2,5°
<b>Awning Hinges</b>								
STORMB26	26/680	100,0	1270,0	2000,0	-	-	16,0 - 18,0	20°

Dimensions of Storm B (balanced) friction hinge 26"

Fitting instructions: Position and Clearances

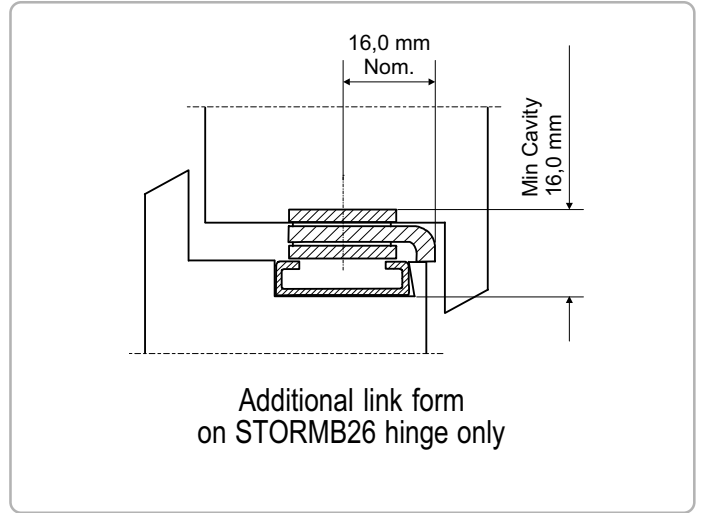
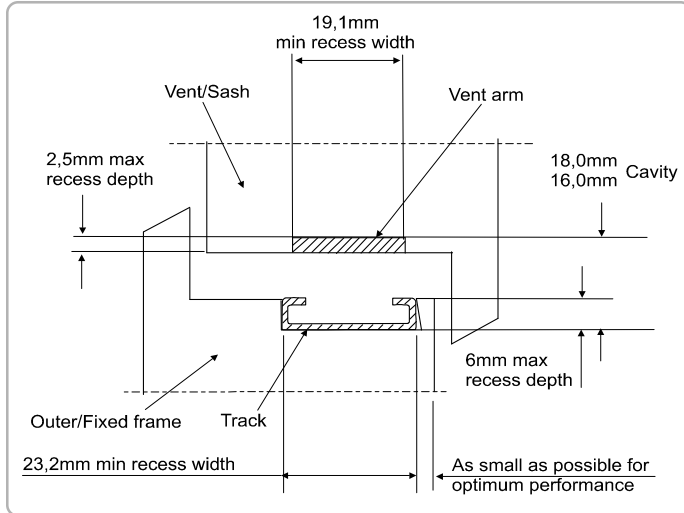

» Dimensions in mm

Fixing hole centre reference

Part Number	Dim. A mm	Dim. B mm	Dim. C mm	Dim. D mm	Dim. E mm	Dim. F mm
STORMB26	63,5	298,2	366,2	320,8	584,4	636,5

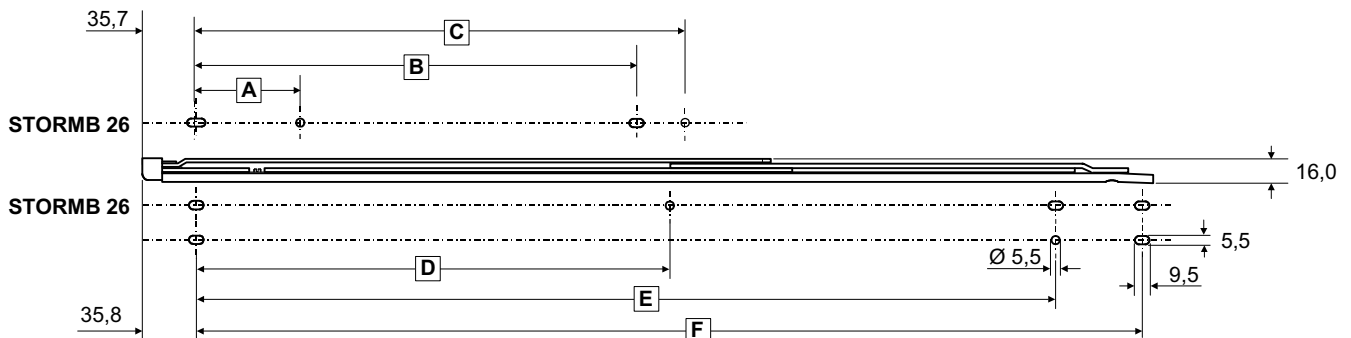
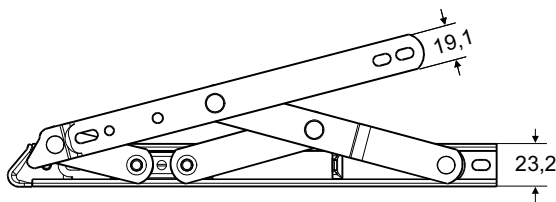

Securistyle Hinge for Windows

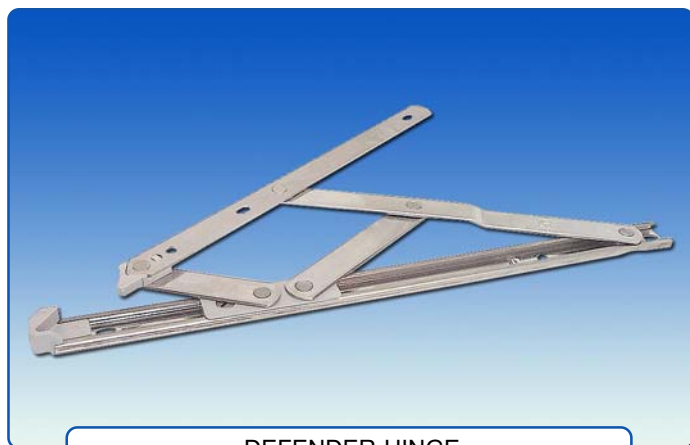

DEFENDER HINGE

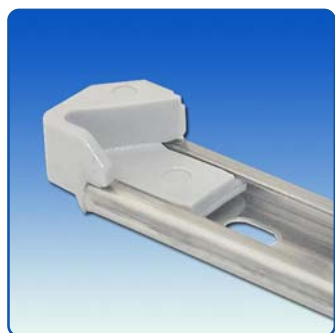

Thermoplastic end cap

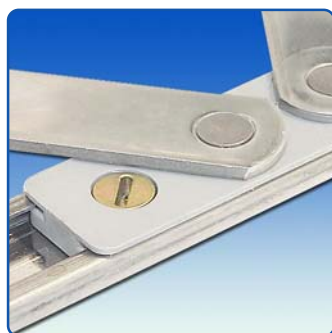

Smooth operation sliders

Standard Defender hinges  
6" - 8" - 10" - 12" - 16" - 20" and 24"

Description	Color	Weight kg	PU	Part Number
Hinge 6"	Stainless Steel	6,5	25	6-C8633-06-P-8
Hinge 8"	Stainless Steel	7,4	25	6-C8633-08-P-8
Hinge 10"	Stainless Steel	9,0	25	6-C8633-10-P-8
Hinge 12"	Stainless Steel	10,7	25	6-C8633-12-P-8
Hinge 16"	Stainless Steel	14,3	25	6-C8633-16-P-8
Hinge 20"	Stainless Steel	16,8	25	6-C8633-20-P-8
Hinge 24"	Stainless Steel	21,2	25	6-C8633-24-P-8

\* = Color

PU = Packaging Unit

ADDITIONAL INFORMATION

- Hinges that can be used to make casement or awning windows
- Hinges fitted with an asymmetric design of locating system which is unique to Securistyle
- All metal components are manufactured from Stainless Steel series 430
- The unique design of the tip offers many advantages such as:
  - Fool-proof locating system for reliable closing
  - Operates smoothly through-out its long life
  - Provides more effective weather and draught proofing

Part Number	Hinge Length in/mm	Max Vent Weight kg	Min Vent Height mm	Max Vent Height mm	Min Vent Width mm	Max Vent Width mm	Cavity Dimensions mm	Opening Angle ± 2,5°
<b>Awning Hinges</b>								
DEFENDER6	6/159	10,0	150,0	300,0	-	-	13,0 - 14,0	50°
DEFENDER8	8/209	12,0	200,0	350,0	-	-	13,0 - 14,0	50°
DEFENDER10	10/259	16,0	275,0	400,0	-	-	13,0 - 14,0	80°
DEFENDER12	12/310	20,0	350,0	550,0	-	-	13,0 - 14,0	80°
DEFENDER16	16/412	21,0	500,0	750,0	-	-	13,0 - 14,0	80°
DEFENDER20	20/513	24,0	700,0	1000,0	-	-	13,0 - 14,0	50°
DEFENDER24	24/615	35,0	850,0	1200,0	-	-	13,0 - 14,0	38°
<b>Casement Hinges</b>								
DEFENDER12	12/310	22,0	-	-	300,0	600,0	16,0 - 18,5	60°
DEFENDER16	16/412	24,0	-	-	400,0	700,0	16,0 - 18,5	60°

Dimensions of Defender friction hinges 6" - 8" - 10" - 12" - 16" - 20" and 24"

» Dimensions in mm

Fixing hole centre reference

Part Number	Dim. A mm	Dim. B mm	Dim. C mm	Dim. D mm
DEFENDER6	-	95,0	-	122,6
DEFENDER8	18,2	119,6	121,6	172,5
DEFENDER10	32,3	152,8	179,9	223,2
DEFENDER12	47,3	188,3	209,5	274,0
DEFENDER16	106,0	228,6	281,2	375,6
DEFENDER20	170,5	271,8	246,8	477,2
DEFENDER24	220,5	322,5	195,0	578,8

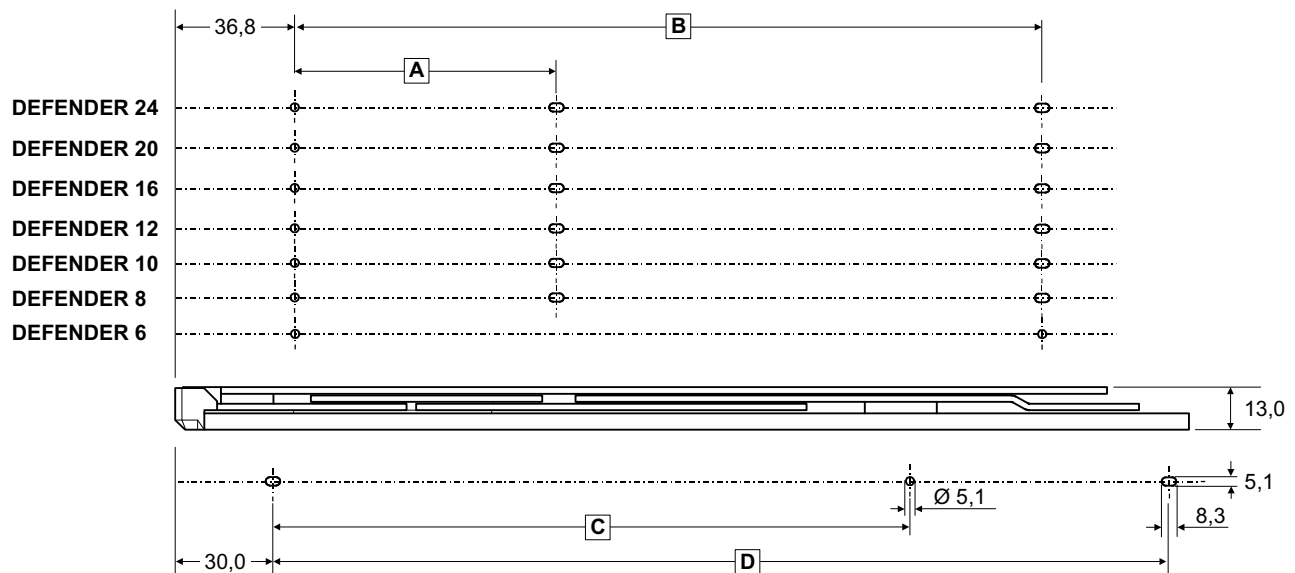
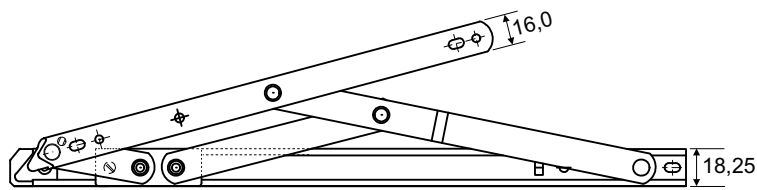

Securistyle Restrictor Stays



DEFENDER RESTRICTOR ARM



Thermoplastic slider

Defender restrictor stays 4" - 6" and 9"

Description	Color	Weight kg	PU	Part Number
Restrictor arm 4"	Stainless Steel	3,0	25	6-C8627-04-P-8
Restrictor arm 6"	Stainless Steel	3,6	25	6-C8627-06-P-8
Restrictor arm 9"	Stainless Steel	4,3	25	6-C8627-09-P-8

\* = Color

PU = Packaging Unit

ADDITIONAL INFORMATION

- All metal components are manufactured from Stainless Steel 430
- The slide is made of Thermoplastic components
- Use for domestic windows
- For large top hung vents, the friction arm can be used as an extra support by fitting it below the existing friction hinge
- This will have the effect of limiting the opening as well as adding stability to the sash

Fitting instructions: Position and Clearances

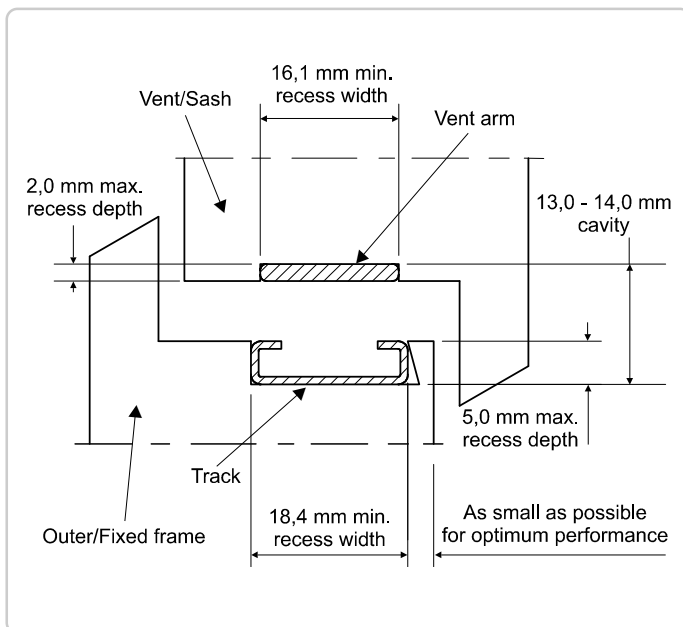

» Dimensions in mm

Part Number	Dim. A mm	Dim. B mm
6-C8627-04	95,0	119,5
6-C8627-06	184,4	119,5
6-C8627-09	229,5	107,0

Securistyle Restrictor Stays

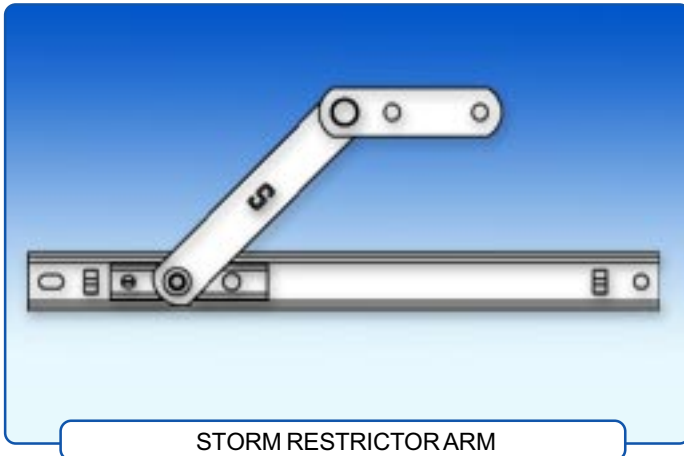

STORM RESTRICTOR ARM

Restrictor stay Storm 8"

Description	Color	Weight kg	PU	Part Number
Restrictor arm 8"	Stainless Steel	4,2	25	6-C8641-08-P-8
		* = Color		PU = Packaging Unit

ADDITIONAL INFORMATION

- All metal components are manufactured from Stainless Steel 304
- Composite Stainless Steel & Acetal slide.
- Use for commercial windows
- For large top hung vents, the friction arm can be used as an extra support by fitting it below the existing friction hinge
- This will have the effect of limiting the opening as well as adding stability to the sash

Fitting instructions: Position and Clearances

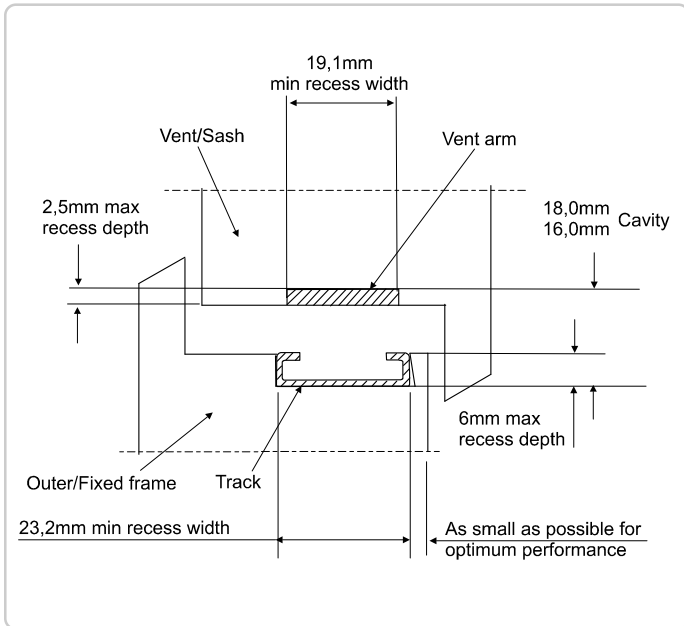

» Dimensions in mm

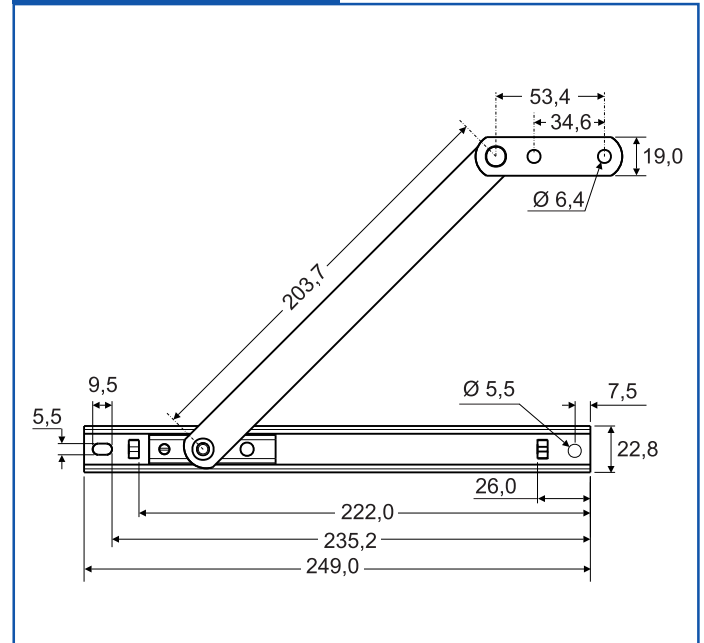

Securistyle Restrictor Stays



Detachable restrictor stays 4" - 6" - 8" and 10"

Description	Color	Weight kg	PU	Part Number
Restrictor arm 4"	Stainless Steel	5,8	50	6-C8628-04-0-8
Restrictor arm 6"	Stainless Steel	7,0	50	6-C8628-06-0-8
Restrictor arm 8"	Stainless Steel	8,0	50	6-C8628-08-0-8
Restrictor arm 10"	Stainless Steel	9,3	50	6-C8628-10-0-8

• Detachable stay is in unit

Release key

Key	Stainless Steel	1	9-C8628-00-0-0
-----	-----------------	---	----------------

\* = Color

PU = Packaging Unit



Dedicated release key allowing the restrictor stay to be detached

ADDITIONAL INFORMATION

- All metal components are manufactured from Stainless Steel 304
- For large top hung vents, the friction arm can be used an extra support by fitting it below the existing friction hinge
- This will have the effect of limiting the opening as well as adding stability to the sash
- Fixed restriction to a wide range of opening angles
- Key releasable restriction for cleaning and maintenance with a special key (Key is not included)

Fitting instructions: Position and Clearances

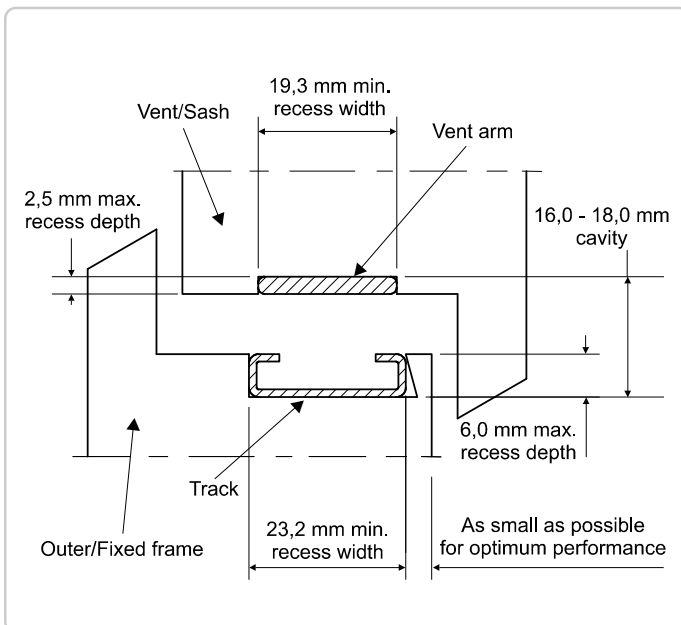

» Dimensions in mm

Part Number	Dim. A mm	Dim. B mm	Dim. C mm	Dim. D mm	Dim. E mm
D-SDR4	101,6	25,5	122,5	136,4	149,5
D-SDR6	152,4	40,5	172,5	186,4	199,5
D-SDR8	203,7	29,5	172,5	186,4	199,5
D-SDR10	254,0	48,3	223,3	237,2	250,3

Accessories



Drop-in limit stop

Description	Color	PU	Part Number
Restrictor for STORMBBS 10"	Stainless Steel	1	9-C8629-10-0-8
Restrictor for STORMBBS 16"	Stainless Steel	1	9-C8629-16-0-8
Restrictor for STORM 22"	Stainless Steel	1	9-C8629-22-0-8

\* = Color      PU = Packaging Unit

**ADDITIONAL INFORMATION**

- Manufactured from Stainless Steel 304
- Use for STORMBBS hinges 10" - 16" and STORM hinge 22"
- Fixing hole in drop-in limit stop. In line with track hole for restricting the hinge to required angle (20°, 30° or 45°)

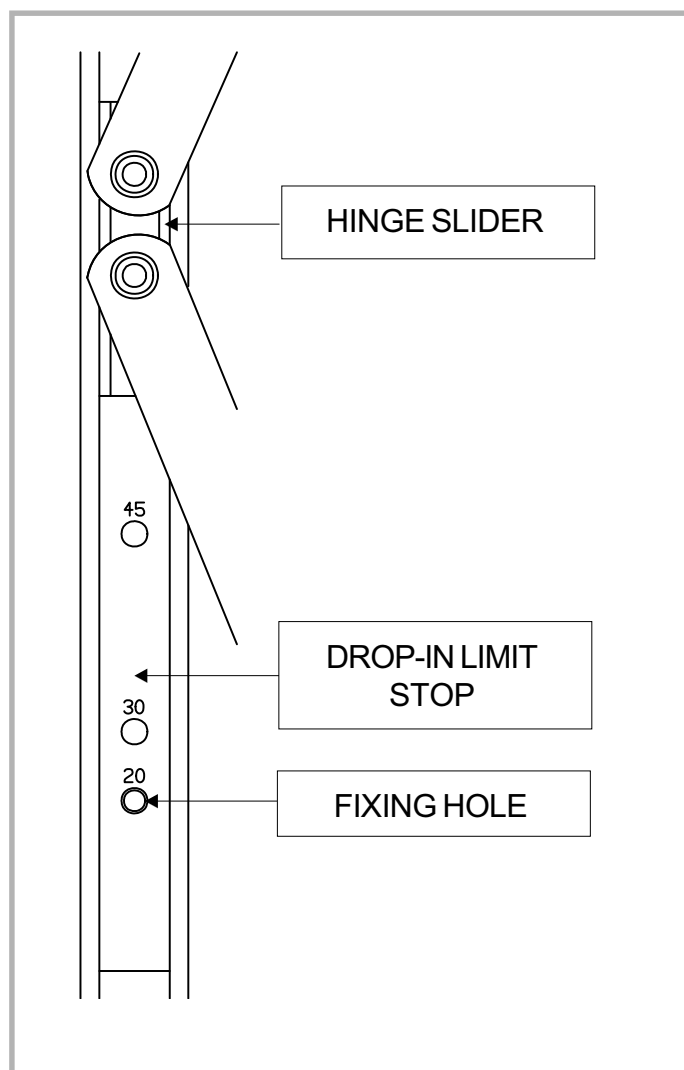

Handing of windows



**(R)**

**RIGHT HAND HINGE**

"R" in part code  
on packaging

**VIEWED FROM OUTSIDE**

**SURFACE  
HINGES**

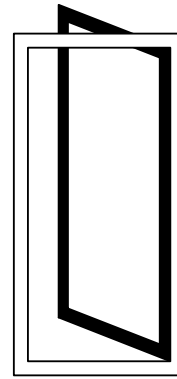
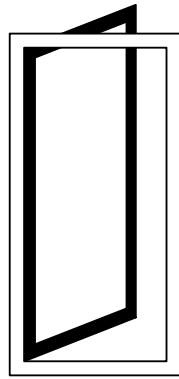

**INSWING  
DOOR**

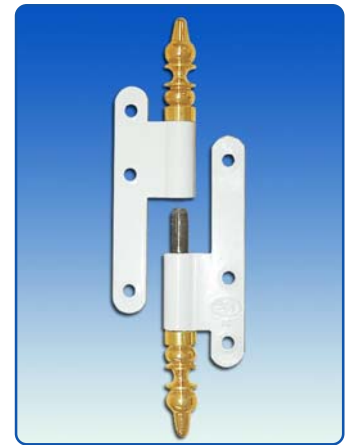
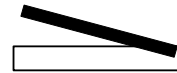
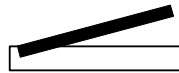

**(L)**

**LEFT HAND HINGE**

"L" in part code  
on packaging

**RECESSED  
HINGES**

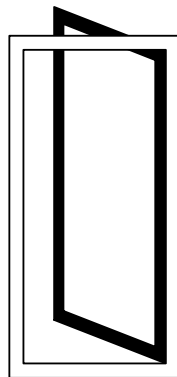
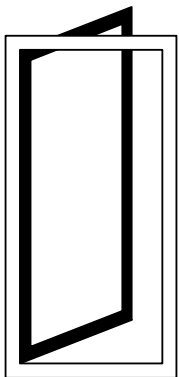

**INSWING  
DOOR**



**(L)**

**LEFT HAND HINGE**

"L" in part code  
on packaging



**(R)**

**RIGHT HAND HINGE**

"R" in part code  
on packaging

VIEWED FROM OUTSIDE

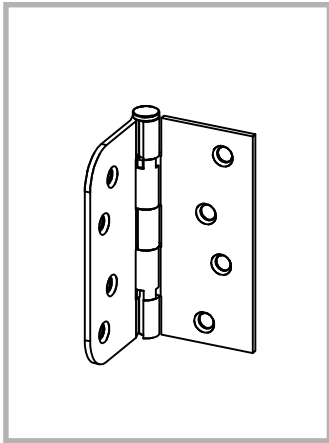

**(L)**

**LEFT HAND HINGE**

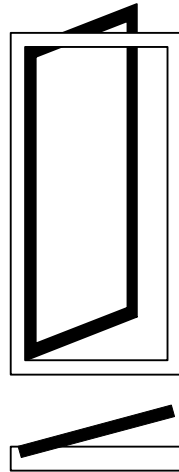

INSWING  
DOOR

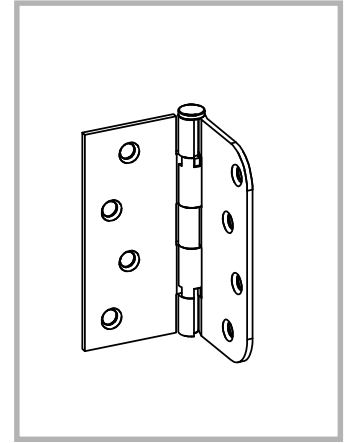
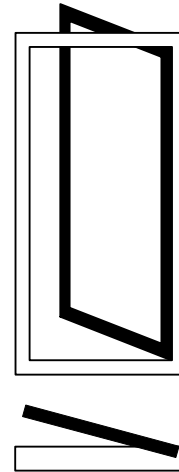

**(R)**

**RIGHT HAND HINGE**

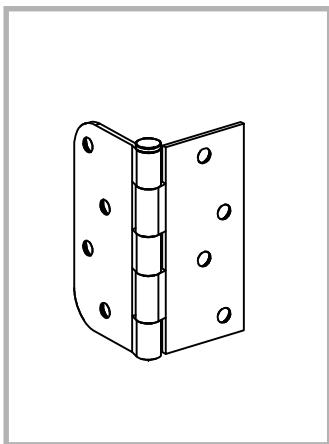

**(R)**

**RIGHT HAND HINGE**

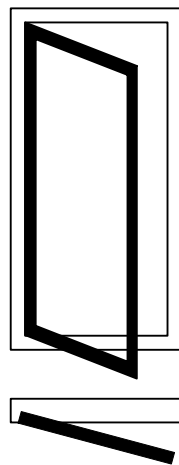

OUTSWING  
DOOR

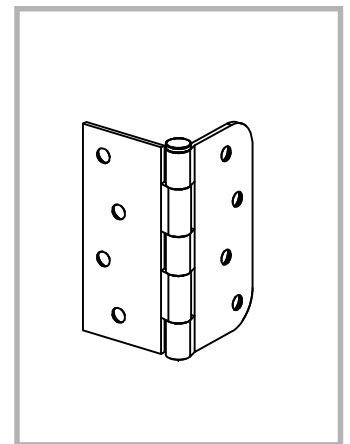
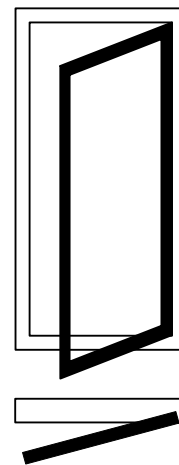

**(L)**

**LEFT HAND HINGE**





Door Hinges



Top view

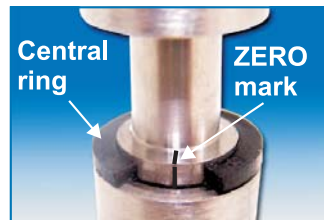

Center view



Bottom view

Adjustable 3 way hinge

Description	Color	Weight kg	PU	Part Number
4" x 4" hinges (square + round corners)	Stainless Steel		1	6-C8060-00-L/R-8
	Antique Brass		1	6-C8060-00-L/R-04
	Polished Brass		1	6-C8060-00-L/R-13
4" x 4" hinges (round + round corners)	Stainless Steel		1	6-C8062-00-L/R-8
	Polished Brass		1	6-C8062-00-L/R-13

\* = Color

PU = Packaging Unit

ADDITIONAL INFORMATION

- Fabrication: Stainless Steel
- Standard 4" X 4" size
- Frame leaf with rounded corners 5/8" R
- Door leaf with square corners
- Adjustable 3 ways:
  - Lateral  $\pm 2$  mm
  - Depth  $\pm 2$  mm
  - Height -3 mm, +5 mm
- For inswing or outswing doors
- Uses with #10 x 5/8", 3/4" and 1" screws

» Dimensions in mm

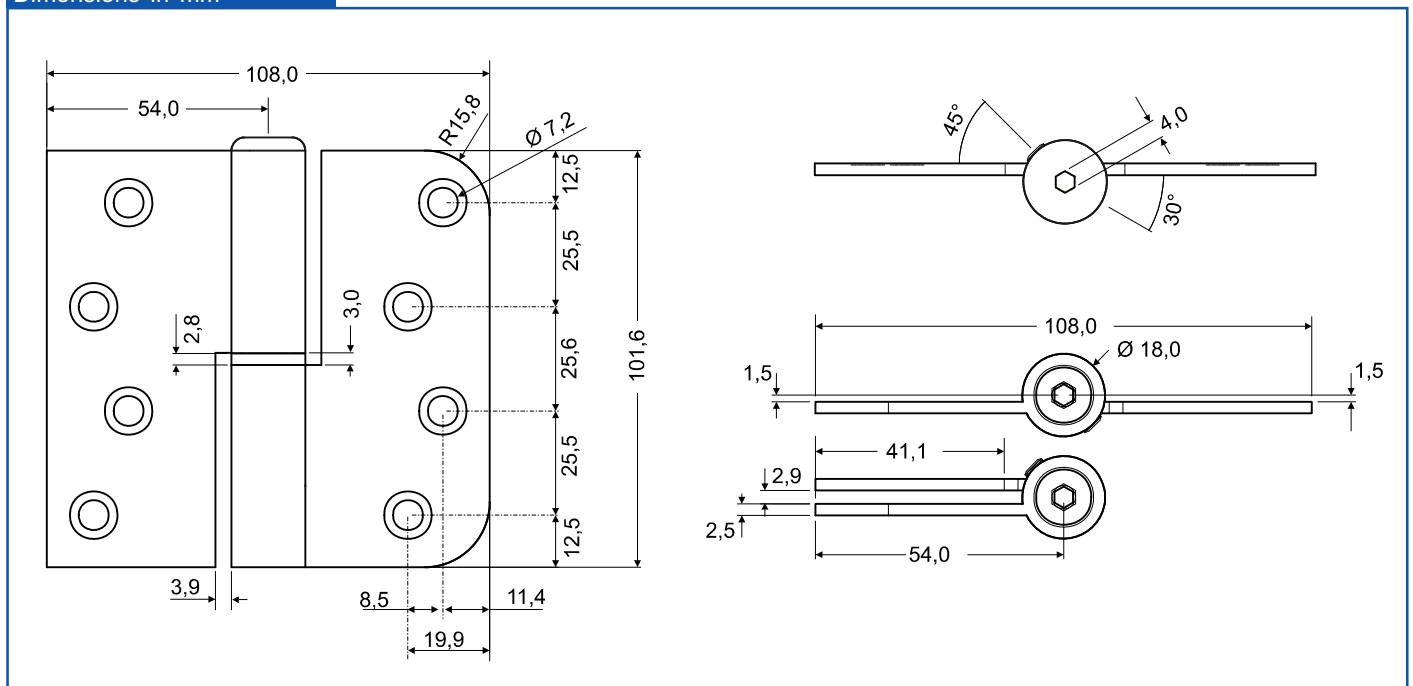





Door Hinges



3-D adjustable hinges

Description	Color	Weight kg	PU	Part Number
Inside installation hinge	Bichromated	8,7	50	6-C8835-00-0-3
Outside installation hinge	Zinc	8,7	50	6-C8836-00-0-1
Outside installation hinge with white covers	Zinc	9,0	50	K-C8836-00-0-7

\* = Color                      PU = Packaging Unit

ADDITIONAL INFORMATION

- Made of steel
- Door hinge for timber sashes up to 130 kg
- Pivoting on ball bearing
- Adjustable on 3 axes
- *Safety set screw on model 6-C8836-00-0-1, for outside installation.*

» Dimensions in mm

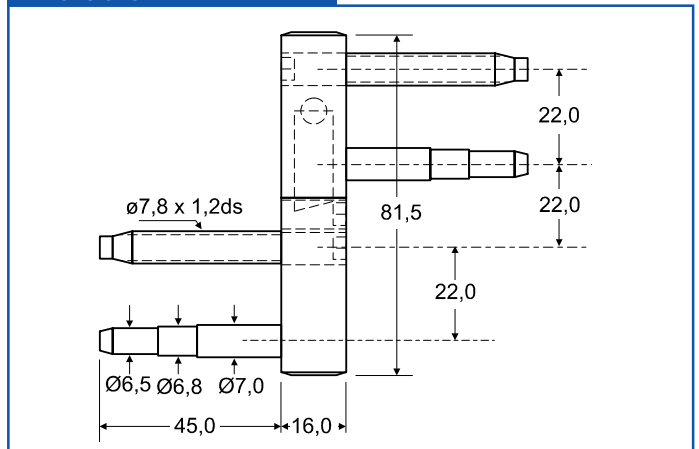

Brass cover

Description	Color	Weight kg	PU	Part Number
Cover	Polished Brass	1,9	100	9-C8839-00-P-3
	Antique Brass	1,9	100	9-C8839-00-P-04
	Pewter	1,9	100	9-C8839-00-P-08

\* = Color                      PU = Packaging Unit

ADDITIONAL INFORMATION

- Made of solid brass
- Lacquered surface
- Used with 6-C8835-00-0-3 and 6-C8836-00-0-1 hinges

» Dimensions in mm

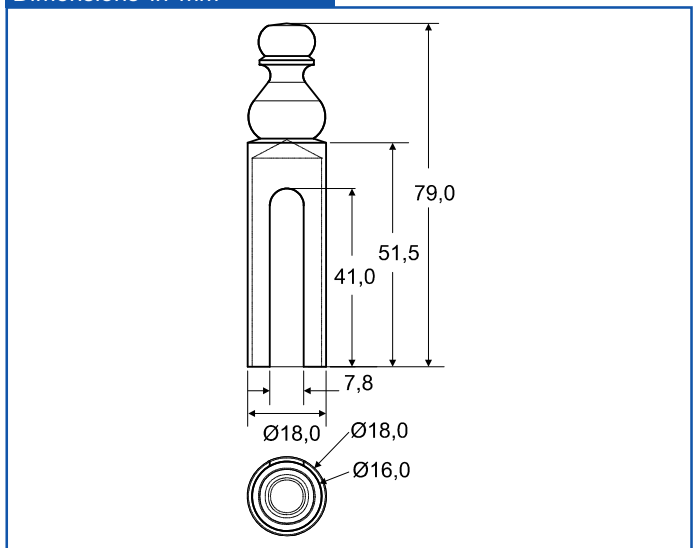

Covers and Shim Set



K-C8830-00-0\*

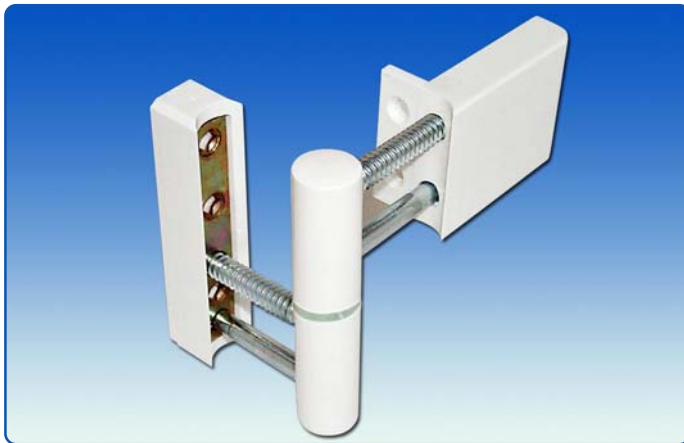

Covers and shim set for series 6-C8835 or 6-C8836

Description	Color	Weight kg	PU	Part Number
Covers	Polished Brass	2,2	25	K-C8830-00-0-3
	Brown	2,2	25	K-C8830-00-0-5
	White	2,2	25	K-C8830-00-0-7

\* = Color                      PU = Packaging Unit

» Dimensions in mm

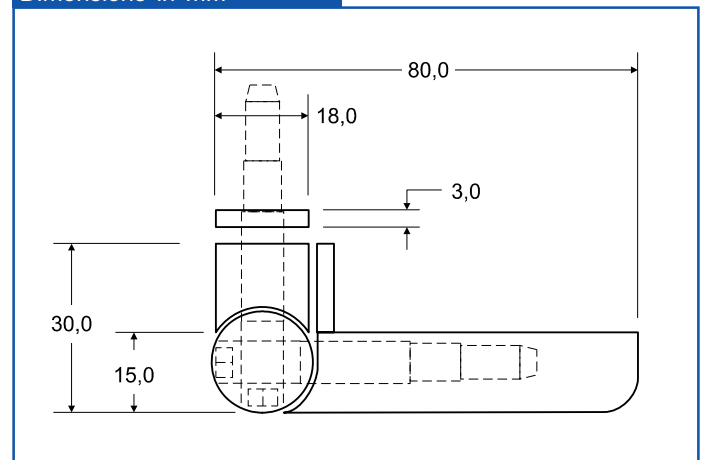

» Dimensions in mm

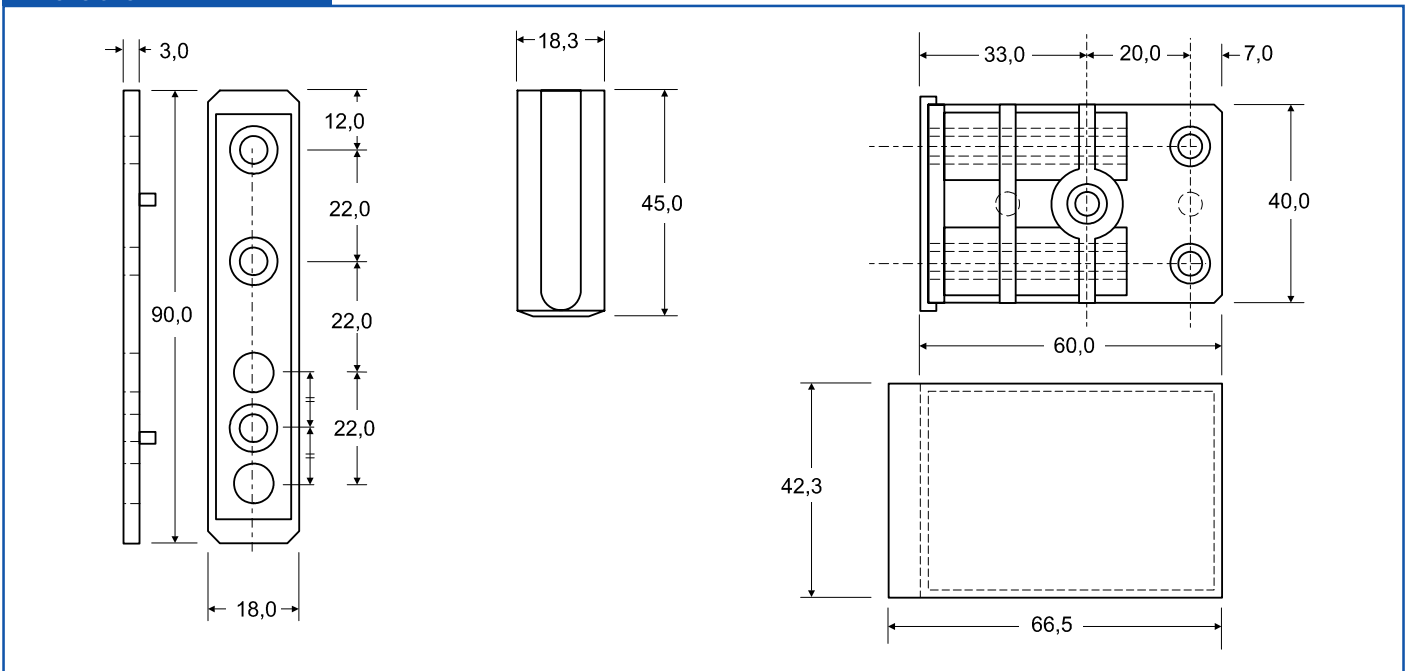

Butt Hinges



6-C8830-00-0-\*

Light duty butt hinge for sashes up to 60 kg

Description	Color	Weight kg	PU	Part Number
Butt hinge	Brown Enamel	3,6	25	6-C8830-00-0-5
	White Enamel	3,6	25	6-C8830-00-0-7

\* = Color

PU = Packaging Unit

**ADDITIONAL INFORMATION**

- Made of steel
- Pivoting on nylon bushings
- Stainless Steel securing pin
- Suitable for side hung sash windows and light doors

» Dimensions in mm

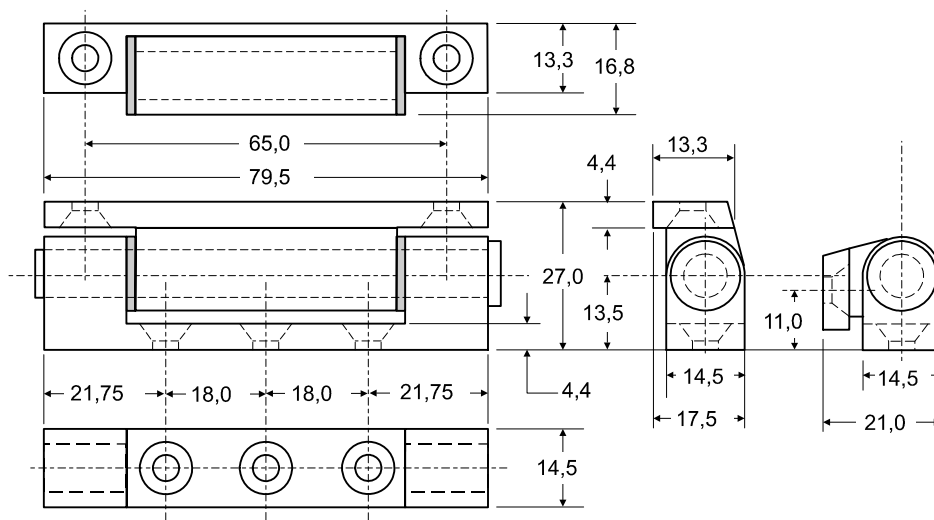

Door Hinges



K-C8870-00-0-7

3-D hinge

Description	Color	Weight kg	PU	Part Number
Set of 3 dimensional fully adjustable hinge	White Enamel		1	K-C8870-00-0-7
		* = Color	PU = Packaging Unit	

**ADDITIONAL INFORMATION**

- Produced from high quality die cast zinc
- Can be used on right and left hung doors
- 6 mm (+4/-2 mm) of height adjustment
- 10 mm (+5/-5 mm) of linear adjustment
- 2 mm (+1/-1 mm) of compression adjustment



» Dimensions in mm

